



OHAUS PS Series

Portable Electronic Pocket Scale



Ohaus PS pocket scales deliver great performance in a unique stylish yet functional design. The combination pan & cover slides back for weighing and forward to cover the display and keys for storage or transport. Two mechanical buttons and a crisp LCD allow for simple, quick operation. With the PS there is no reason to settle for other brands when you can have an Ohaus.

Standard Features Include:

- ABS plastic front panel with painted carbon steel rear housing and mounting bracket
- Sliding pan & cover protects display and keys and prevents load cell damage in transport
- Smaller size than most pocket scales allowing a comfortable fit in your pocket
- Fast and easy battery replacement with "pop-out" design

PS Series Portable Electronic Pocket Scale

Specifications

Model	PS121	PS251
Capacity (g)	120	250
Readability (g)	0.1	
Repeatability (Std. Dev.) (g)	0.1	
Linearity (g)	0.1	
Off-Center Load (g)	0.1	
Weighing Units	g, oz, ozt, dwt	
Power	2 lithium batteries (included)	

Outline Dimensional Drawings

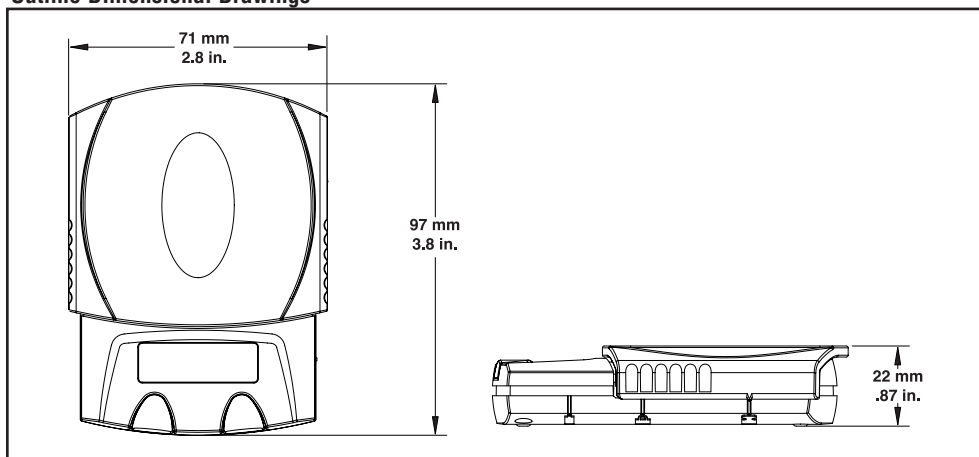

Standard Features

High contrast LCD, stability indicator, overload and underload indicators, low battery indicator, auto shut-off.

Accessories

Calibration Masses

100g for PS12180780036

200g for PS25180780047

Industry Leading Quality and Support

All OHAUS PS Pocket Scales are manufactured under an ISO 9001:2008 Registered Quality Management System. Our rugged construction and stringent quality control have been hallmarks of all OHAUS products for nearly a century.

OHAUS CORPORATION

* 19A Chapin Road
P.O. Box 2033
Pine Brook, NJ 07058 USA

Tel: 800.672.7722
973.377.9000
Fax: 973.944.7177

www.ohaus.com

*With offices throughout Europe,
Asia, and Latin America*

* **ISO 9001:2008**
Registered Quality Management System