

Large Display pH Pens

850050, 850051, 850052

SPER
SCIENTIFIC

Environmental Measurement Instruments

Large Display pH Pens - 850050, 850051, 850052

Copyright ©2015 by Sper Scientific
ALL RIGHTS RESERVED. Printed in the USA

The contents of this manual may not be reproduced or transmitted in any form or by any means electronic, mechanical, or other means that do not yet exist or may be developed, including photocopying, recording, or any information storage and retrieval system without the express permission from Sper Scientific.

NOTE REMOVING PROTECTIVE CAP:



Hold the blue ring firmly in place with one hand, rotate the semi-transparent bottle $180^{\circ} \sim 360^{\circ}$ clockwise. This will loosen the gasket to allow you to pull the cap off. Reverse the procedure to put the cap back on.

TABLE OF CONTENTS

1. INTRODUCTION	3
2. MATERIALS SUPPLIED.	3
3. FRONT PANEL DESCRIPTION	4
4. CALIBRATION INSTRUCTIONS	5
5. MEASUREMENT PROCEDURE	6
6. BATTERY REPLACEMENT	9
7. TROUBLESHOOTING	10
8. SPECIFICATIONS.	11
9. WARRANTY.	12

INTRODUCTION

These are simple and easy to use waterproof pH Pens. 850050 measures 2~14 pH. 850051 & 850052 features Hold and Automatic Temperature Control (ATC), and measures from 0~14 pH.

MATERIALS SUPPLIED

Meter

Batteries

Instruction Manual

FRONT PANEL DESCRIPTION

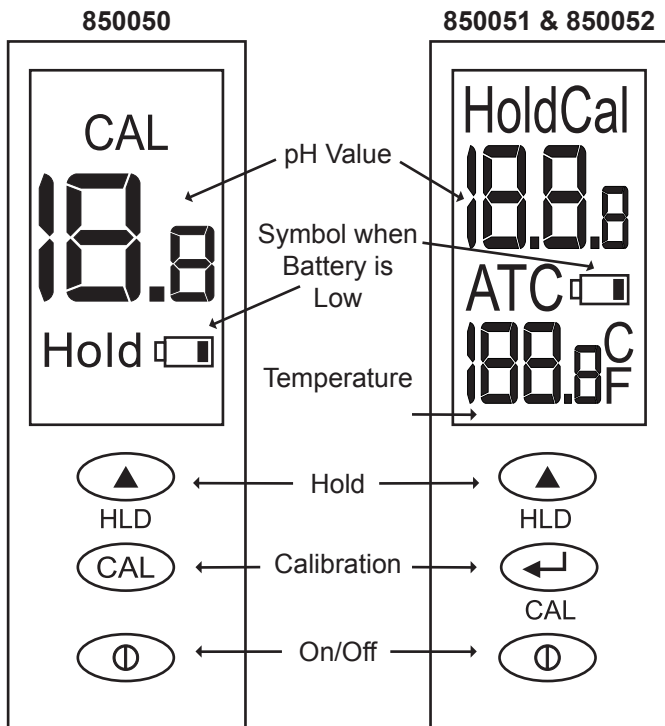

First Use: If the unit fails to turn on, check that the batteries are working and properly installed.

OPERATING INSTRUCTIONS

1. Calibrate routinely before use, anytime the readings seem erratic, and whenever the batteries are replaced.
2. Remove the protective cap.
3. Clean the electrode with de-ionized/distilled water. Note: Crystals may form in the cap and these can be soaked or rinsed away.
Do not touch or rub the glass bulb.
4. Before first use or after extended storage, soak the electrode in KCL (potassium chloride) solution for 10~30 minutes.
5. Press Ⓚ >1 sec to turn on the unit.
6. For 1-point calibration, dip/stir the electrode into pH 7 buffer solution and press the CAL button.
If the probe is damaged or cannot detect the buffer, the unit automatically exits calibration mode after 10 seconds.
7. During calibration, "CA" flashes on the display.
8. Then, "CAL" and the pH value are shown.
The ATC value is also shown in models 850051 & 850052.

9. "SA" (save) is displayed as the calibration point is saved.
10. "En" (end) (850050, 850051), or "End" (850052) displays when the calibration ends.
11. For 2 or 3 point calibration, start with pH 7, then repeat the above steps for pH 4 and/or pH 10.
12. For the most accurate readings, the temperature of the sample and calibration solutions should be similar.
13. Repeat the above procedures until readings stabilize.
14. NOTE: If the buffer needs to be adjusted, press ▲ to adjust the displayed value. "SA" (save) is displayed, followed by "En" (850050, 850051), or "End" (850052).

MEASUREMENT PROCEDURE 850050

1. Calibrate routinely before use.
2. Remove the protective cap and clean the electrode with de-ionized/distilled water. Do not touch the glass bulb.
3. Press **Ⓚ** >1 sec to turn on the unit.

4. Dip/stir the electrode into the sample.
5. The pH value is displayed.
6. “- -” is displayed when the pH sample is out of range.
7. During measurement, press ▲ to freeze the reading on the LCD.
“Hold” is displayed. Press ▲ again to return to normal measurement.
8. The pH Pen automatically shuts off after 20 minutes of inactivity. To disable this feature, start with the unit off, then simultaneously press the CAL and ▲ buttons. Release both buttons when “n” is displayed. The unit returns to measurement mode.
9. After use, turn off the unit and rinse the electrode.
10. Protect the electrode’s lifespan by adding a few drops of KCL (potassium chloride) solution into the protective cap before storage.
11. Always keep the protective cap on when the unit is not in use.

MEASUREMENT PROCEDURE 850051 & 52

1. Calibrate routinely before use.
2. Remove the protective cap and clean the electrode with de-ionized/distilled water.
Do not touch the glass bulb.
3. Press **⓪** >1 sec to turn on the unit.
4. Dip/stir the electrode into the sample.
5. The pH value is displayed.
6. “- - -” is displayed when the pH sample is out of range.
7. “H” or “L” is displayed when the temperature is out of range.
8. To switch between °F and °C, start with the unit off, then simultaneously press CAL and **⓪** .
9. Release both buttons when “C” or “F” is shown.
10. Press **▲** to select the preferred unit, then press CAL to save.
11. “SA” (save) is displayed and the unit returns to measurement mode.
12. During measurement, press **▲** to freeze the reading on the LCD. “Hold” is displayed. Press **▲** again to return to normal measurement.

13. The pH Pen automatically shuts off after 20 minutes of inactivity. To disable this feature, start with the unit off, then simultaneously press the **⓪** and **▲** buttons. Release both buttons when “n” is displayed. The unit returns to measurement mode.
14. After use, turn off the unit and rinse the electrode.
15. Protect the electrode’s lifespan by adding a few drops of KCL (potassium chloride) solution into the protective cap before storage.
16. Always keep the protective cap on when the unit is not in use.

BATTERY REPLACEMENT

1. Replace all 4 LR44 batteries when the low battery icon is flashing, or when troubleshooting (next page) fails.
2. Unscrew the cover and install the batteries with the flat positive (+) side facing the springs.
3. Do not remove the O-ring.
4. Remove the batteries when the unit is not in use for an extended period.

TROUBLESHOOTING

1. If there is no display, or you have erratic readings after having soaked the electrode in KCL (potassium chloride) solution for at least 1 hour prior to calibration, check the continuity of the batteries by removing them for 1 minute, then reinsert.
2. Slow Response: Soak the electrode in KCL (potassium chloride) solution for 10-15 minutes, then rinse with distilled/de-ionized water.
3. “ - - - ” displays when the pH sample is too acidic or too alkaline.
4. No Display: Be sure to press **⓪** for at least one second. If the problem persists, see Battery Replacement (previous page).
5. If your readings are still erratic after calibration, soak the electrode for 10 to 30 minutes in KCL (potassium chloride) solution.
6. Note: It is normal for the pH value to fluctuate quickly when the electrode is exposed to air and not immersed.

SPECIFICATIONS

Model	850050	850051	850052
Range	2 ~ 12 pH	0 ~ 14 pH	0 ~ 14 pH
Res	0.1 pH	0.1 pH 0.5°F/°C	0.01 pH 0.1°F/°C
Accuracy	±0.3 pH	±0.2 pH	±0.05 pH
Adjustable Calibration Points	pH 4 pH 7 pH 10	3.5 ~ 4.5 6.5 ~ 7.5 9.5 ~ 10.5	
Operating Environment	31 ~ 122°F / 0 ~ 50°C & >80 RH		
Weight	2.3 oz (65 g) with battery		
Dimensions	6½" × 1½" × 1½" (165 × 38 × 38 mm)		

WARRANTY

Sper Scientific warrants this product against defects in materials and workmanship for a period of **1 year** from the date of purchase, and agrees to repair or replace any defective unit without charge. If your model has since been discontinued, an equivalent Sper Scientific product will be substituted if available. This warranty does not cover probes, batteries, or damage resulting from accident, misuse, or abuse. To obtain warranty service, ship the unit postage prepaid to:

SPER SCIENTIFIC
8281 E. Evans Rd. Suite #103
Scottsdale, AZ 85260
Email: info@sperscientific.com

The defective unit must be accompanied by a description of the problem and your return address. Register your product online at www.sperscientific.com, or return your warranty card within 10 days of purchase.

02/25/15