

**Large Display  
Salinity &  
Conductivity Pens**

850036 & 850037

SPER  
SCIENTIFIC

---

Environmental Measurement Instruments

# **Large Display Salinity & Conductivity Pens**

**850036 & 850037**

Copyright ©2013 by  
Sper Scientific  
ALL RIGHTS RESERVED  
Printed in the USA

The contents of this manual may not be reproduced or transmitted in any form or by any means electronic, mechanical, or other means that do not yet exist or may be developed, including photocopying, recording, or any information storage and retrieval system without the express permission from Sper Scientific.

Sper Scientific  
8281 E. Evans Rd., Suite #103  
Scottsdale, AZ 85260  
(480) 948-4448

# TABLE OF CONTENTS

INTRODUCTION . . . . .	4
FEATURES . . . . .	5
MATERIALS SUPPLIED . . . . .	5
POWER SUPPLY . . . . .	6
LCD DISPLAY . . . . .	6
APPENDICES . . . . .	45
BATTERY REPLACEMENT . . . . .	52
MAINTENANCE . . . . .	53
TROUBLESHOOTING . . . . .	54
WARRANTY . . . . .	56
<b>850036 SALINITY PEN . . . . .</b>	<b>7</b>
SET UP . . . . .	8
CALIBRATION . . . . .	12
MEASUREMENT PROCEDURES . . . . .	16
SPECIFICATIONS . . . . .	19
ERROR CODES . . . . .	20
<b>850037 CONDUCTIVITY PEN . . . . .</b>	<b>23</b>
SET UP . . . . .	24
CALIBRATION . . . . .	32
MEASUREMENT PROCEDURES . . . . .	38
SPECIFICATIONS . . . . .	42
ERROR CODES . . . . .	43

## INTRODUCTION

The Sper Scientific Large Display Salinity (Model 850036) and Conductivity (Model 850037) Pens provide highly stable and accurate readings with a large LCD that simultaneously displays the parameter being measured and temperature in °C or °F. The pens are designed for simple one-hand operation. The case is IP65 waterproof, and will float if accidentally dropped into the water.

Salinity is displayed not as a percentage but as parts per thousand (ppt), which is approximately grams of salt per liter of solution.

Conductivity is displayed as mhos per centimeter (M/cm) or siemens per centimeter (S/cm). Because a mho (or siemen) is a large unit, microsiemen or millisiemen typically is used ( $\mu\text{S/cm}$ ,  $\text{mS/cm}$ ).

## **FEATURES**

- IP65 waterproof housing
- Dual display with ATC
- Data hold
- Pen size for portability
- Built-in probe with protective cap
- One touch, multi-point calibration
- Auto-power-off
- Low battery indicator

## **MATERIALS SUPPLIED**

- 4 LR44 button cell batteries
- Instruction Manual

## POWER SUPPLY

The pen is powered by 4 LR44 batteries. Check the batteries when:

- Using the unit for the first time
- The low battery indicator appears on the LCD
- The pen will not turn on

## LCD DISPLAY

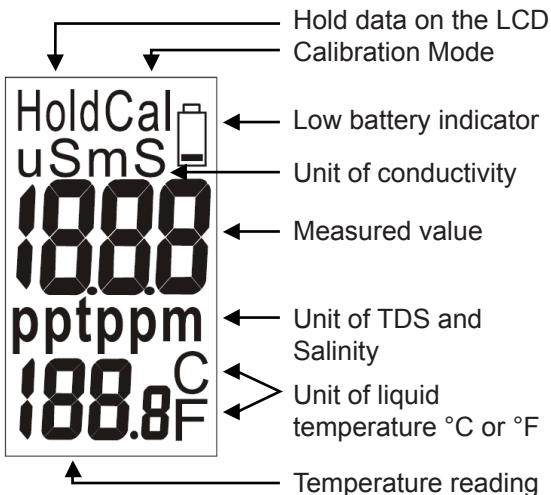

# **Large Display Salinity Pen**

850036

## SETUP MODE

The advanced Setup Mode allows you to customize the pen's preferences and defaults:

1. Press **SET** to turn the pen **on**.
2. From Measurement Mode, press **SET** for more than 2 seconds to enter Setup Mode and change parameters.

### Temperature Units (tUt)

To select the Celsius or Fahrenheit temperature scale:

1. Press **SET** for 2 seconds to enter setup.
2. "t" will appear on the primary display of the LCD and "P1.0" will appear on the secondary display.
3. Press **SET** again for less than one second to enter the unit setting.
4. Press ▲ or ▼ to select C (Celsius) or F (Fahrenheit). Press **SET** for less than one second to confirm the unit selection. Press **SET** for more than 2 seconds to return to P1.0 without saving.



5. When in P1.0, press ▲ to advance to the next setup function or press **SET** for more than 2 seconds to return to Measurement Mode.

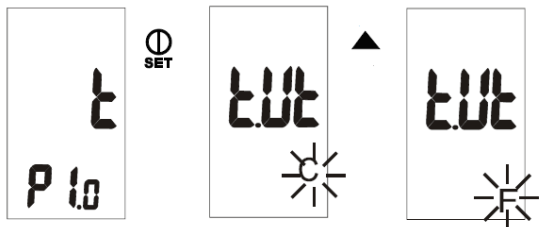

## Resetting the Pen (rSt)

When the pen is reset, all parameters will be reset to factory default values.

1. Press **SET** for 2 seconds to enter setup.
2. Press ▲ to select the reset pen setting. "rst" will appear on the main display of the LCD and "P3.0" will appear on the secondary display.
3. Press **SET** again for less than one second to enter the reset setting.
4. Press ▲ to select Y (yes) or N (no).

5. Press **SET** for less than one second to confirm the selection or press **SET** for more than 2 seconds to return to P3.0 without saving.
6. When in P3.0, press ▲ to advance to the next setup function or press **SET** for more than 2 seconds to return to Measurement Mode.

## **Calibration Review (CAL)**

1. Press **SET** for 2 seconds to enter setup.
2. Press ▲ to select the calibration review setting. “CAL” will appear on the primary display of the LCD and “P4.0” will appear on the secondary display.

### Range 1 Calibration Information:

3. When in P4.0, press **SET** for less than one second to enter P4.1 to review the last calibration concentration. If the pen is not yet calibrated, “---” will appear on the LCD.

## Range 2 Calibration Information:

4. When in P4.1, press ▲ to enter P4.2 to review the last calibration concentration. If range 2 is not yet calibrated, “---” will appear on the LCD.
5. When in P4.1 or P4.2, press **SET** for less than one second to confirm and return to P4.0.
6. When in P4.0, press ▲ to advance to the next setup function or press **SET** for more than 2 seconds to return to Measurement Mode.

### **Note...**

P4.1 and P4.2 Modes allow review of the calibration information but are not used during the calibration procedure.

## **Selecting the Measurement Range (rAn)**

There are two measurement ranges.  
The pen defaults to auto-ranging:

	Salinity
Range 1	0 ~ 10.00 ppt
Range 2	10.1 ~ 70.0 ppt

To manually select the measurement range:

1. Press **SET** to turn the pen **on**.
2. Press **▲** for more than 2 seconds to select range 1. Press **▲** for more than 2 seconds to select range 2.

## **CALIBRATION**

### **Selecting the Calibration Standard Solution**

For best results, select a NaCl standard near the sample value that you are measuring. Alternatively, use a calibration solution value that is approximately  $\frac{2}{3}$  of the full scale of the measurement range that you plan to utilize.

Do NOT reuse the calibration solution. Contaminants in the solution will affect the calibration and the accuracy. Use fresh solution each time.

The previous calibration data will be replaced after re-calibrating. However,

the pen will retain the calibration data for other ranges that have not yet been recalibrated.

## Selecting the Calibration Schedule

Calibration is necessary and should be performed regularly. Soak the probe for 15 minutes before calibration or measurement to minimize drift. If the pen is used in the mid ranges, calibrate the unit monthly.

If the measurement is performed at extreme temperatures or within the concentration listed below, calibrate the unit weekly.

Model	Concentration	
Salinity Pen	< 0.10 ppt	> 5.0 ppt

## Salinity Calibration

1. Place the probe into deionized or distilled water for about 30 minutes to rinse the probe.
2. Select the NaCl standard for calibration.
3. Pour 3 cm (deep) of solution into two separate containers (A & B).
4. Press **SET** to turn the pen **on**.
5. Rinse the probe in one of the containers. Gently stir the probe.
6. Dip the rinsed probe into the other container. Tap the probe on the bottom of the container to remove air bubbles. Let the probe stabilize to the solution temperature (allow 15 minutes).
7. Press **CAL** for more than 2 seconds to begin calibration. "CAL" and the salinity value of the solution will flash on the LCD.
8. Press **▲** or **▼** to adjust the value on the primary display to match the value of the standard buffer. You can adjust the salinity reading  $\pm 30\%$  from the detected value. If the detected value and the standard value differ by more than  $\pm 30\%$ , clean or replace the pen.

9. When “CAL” stops flashing on the LCD, press **SET** for less than 1 second to confirm the value. The pen will return to Measurement Mode for salt measurement. To exit Calibration Mode without saving, press **SET** for more than 2 seconds. This allows you to retain the pen’s previous calibration data for the current range as you proceed. If “CAL” flashes on the LCD continually, check that the calibration solution is stable and that the input value (Step 8) is correct.
10. Repeat Steps 1-9 for other ranges as needed.

**Note...**

If the standard value is over the measuring range or 10% less, the displayed value will be equal to the range limit or 10% of the range limit.

## MEASUREMENT PROCEDURES

1. Remove the probe cover from the pen.
2. Press **SET** to turn the pen **on**.
3. The pen defaults to auto-ranging mode. The auto-ranging function determines and selects a range that will provide the greatest resolution and accuracy.
4. To manually select the measurement range: Press **SET** to turn the pen **on**. Press ▲ for more than 2 seconds to select range 1. Press ▲ for more than 2 seconds to select range 2.

### **Note...**

Accuracy is a percent of full-scale; use your pen in the lowest range to achieve the greatest accuracy. Error codes E02/E03 will appear on the LCD if the measured value is below or above the limit value. Please re-select the range.



5. Rinse the probe tip with de-ionized or distilled water before use to remove any impurities adhering to the probe. If the probe tip is dehydrated, soak it for 30 minutes to prevent contaminants from slowing down the measurement and accuracy.
6. Immerse the probe tip completely into the sample. Ensure that there are no air bubbles trapped in the probe slot. Gently stir the probe to remove air bubbles, ensuring that the probe tip is submerged while stirring.
7. Stir the probe gently to create a uniform sample. Wait about 15 minutes for the reading to stabilize.
8. The unit of measure will flash on the LCD to indicate that the pen is in Measurement Mode. When the reading is stable, the unit of measure will stop flashing.

## Hold Function

1. Press **HLD** to freeze the current readings on the display. "Hold" will appear on the LCD.

2. Press **HLD** again to release the hold function.

## Turning the Pen Off

1. Press **SET** to turn the pen **off** from Measurement Mode.
2. To turn the pen **off** from Setup Mode, press **SET** for more than 2 seconds to return to Measurement Mode, then press **SET** again.

## Auto Power Off

1. To save battery life, the pen will automatically turn **off** after 20 minutes of inactivity. To disable this function:
2. Press **SET** to turn the pen **off**.
3. Press **SET** and **▼** simultaneously until “n” appears on the LCD. Release the keys to return to Measurement Mode. Auto-power-off is now disabled.

### Note...

The auto-power-off function will be enabled each time the pen is turned **off**.

## SPECIFICATIONS

Accuracy	$\pm 1\%$ Full Scale $\pm 1$ digit (0.0~10.0 ppt) or $\pm 2\%$ Full Scale $\pm 1$ digit (10.1~70.0 ppt)
Range	0.00~10.00 ppt (NaCl) or 10.1~70.0 ppt (NaCl)
Resolution	0.01 ppt or 0.1 ppt
Calibration	One point per range
TDS Factor	Built-in NaCl conductivity to TDS factor
Temperature Coefficient	Built-in NaCl temperature coefficient
Reference Temperature	Fixed at 25°C
Operating Temperature	0~50°C (32~122°F)
Battery Life	>80 hours continuous use
Weight	2.5 oz (68 g)
Dimensions	6½" x 1½" x 1½" (165 x 38 x 38 mm)

## ERROR CODES

### Salinity

- - - The pen is in manual ranging 1 but the salinity measurement is higher than 10.0 ppt; Press ▲ for more than 2 seconds to change to manual ranging 2 or auto-ranging mode.
- E03 The salt value is over the range limit (70.0 ppt) or the pen is damaged; Put the pen in standard buffer solution (the buffer concentration must be lower than the range limit). If E03 still appears, send the pen to Sper Scientific for repair.
- E04 Error in measuring original data (damaged temperature sensor, temperature out of specifications or salinity error). E04 will disappear when the original error is resolved.

## Temperature

- E01 The temperature circuit is damaged; Send the pen to Sper Scientific for repair.
- E02 The temperature value is below the range limit ( $0^{\circ}\text{C}$ ) or the temperature circuit is damaged; Place the pen in room temperature for 5 minutes, if E02 still appears, send the pen to Sper Scientific for repair.
- E03 The temperature value is above the range limit ( $50^{\circ}\text{C}$ ) or the temperature circuit is damaged; Place the pen in room temperature for 5 minutes, if E03 still appears, send the pen to Sper Scientific for repair.



# **Large Display Conductivity Pen**

850037

## SETUP MODE

The advanced Setup Mode allows you to customize the pen's preferences and defaults:

1. Press **SET** to turn the pen **on**.
2. From Measurement Mode, press **SET** for more than 2 seconds to enter Setup Mode and change parameters.



## Temperature Units (tUt)

To select the Celsius or Fahrenheit temperature scale:

1. Press **SET** for 2 seconds to enter setup.
2. “t” will appear on the primary display of the LCD and “P1.0” will appear on the secondary display.
3. Press **SET** again for less than one second to enter the unit setting.
4. Press ▲ or ▼ to select C (Celsius) or F (Fahrenheit). Press **SET** for less than one second to confirm the unit selection. Press **SET** for more than 2 seconds to return to P1.0 without saving.
5. After confirming the temperature unit selection, you may continue to set other temperature related parameters by pressing **SET** for more than 2 seconds to return to P1.0.
6. When in P1.0, press **SET** for more than 2 seconds to return to Measurement Mode.

## Reference (Normalization) Temperature (tnr)

After saving the temperature unit setting, the pen will automatically enter the reference temperature setup.

1. Press **▲** to select 20°C or 25°C.
2. Press **SET** for less than one second to confirm the value or press **SET** for more than 2 seconds to return to P1.0 without saving.

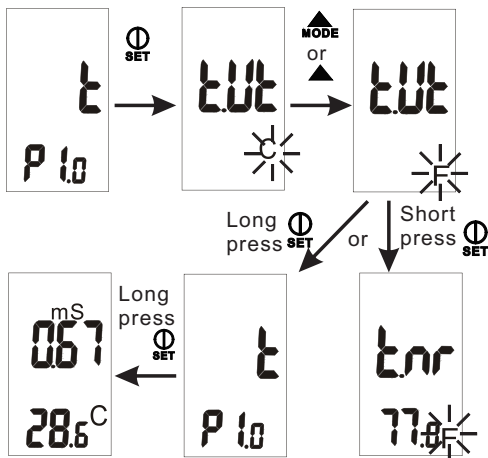

## Temperature Coefficient (tCo)

1. Press ▲ or ▼ to change the temperature coefficient from 0.0 to 4.0.
2. Press **SET** for less than one second to confirm the value or press **SET** for more than 2 seconds to return to P1.0 without confirming the temperature coefficient value.

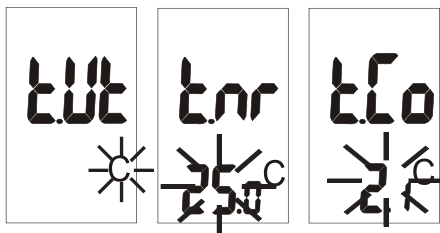

## Resetting the Pen (rSt)

When the pen is reset, all parameters (including calibration information) will be reset to factory default values.

1. Press **SET** for 2 seconds to enter setup.
2. Press **▲** to select the reset pen setting. “rst” will appear on the main display of the LCD and “P3.0” will appear on the secondary display.
3. Press **SET** again for less than one second to enter the reset setting.
4. Press **▲** to select Y (yes) or N (no).
5. Press **SET** for less than one second to confirm the selection or press **SET** for more than 2 seconds to return to P3.0 without saving.

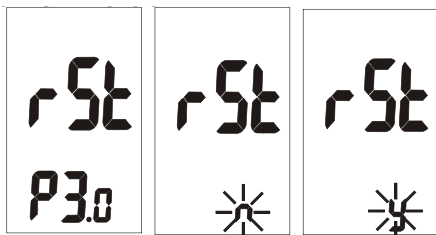

## Calibration Review (CAL)

1. Press **SET** for 2 seconds to enter setup.
2. Press **▲** to select the calibration review setting. “CAL” will appear on the primary display of the LCD and “P4.0” will appear on the secondary display.

### Range 1 Calibration Information:

3. When in P4.0, press SET for less than one second to enter P4.1 to review the last calibration concentration. If the pen is not yet calibrated, “---” will appear on the LCD.

### Range 2 Calibration Information:

4. When in P4.1, press **▲** to enter P4.2 to review the last calibration concentration. If range 2 is not yet calibrated, “---” will appear on the LCD.

### **Note...**

When in P4.1 or P4.2, press **SET** for less than one second to confirm and return to P4.0.

P4.1 and P4.2 Modes allow review of the calibration information but are not used during the calibration procedure.

When in Temperature Parameter (P1.0), Resetting the Pen (P3.0) or Calibration Review (P4.0) Setup Modes, press **SET** for more than 2 seconds to return to Measurement Mode.

## Selecting the Measurement Range (rAn)

There are two measurement ranges.

The pen defaults to auto-ranging

	Conductivity
Range 1	0 ~ 1999 $\mu$ S
Range 2	0 ~ 19.99 mS

To manually select the measurement range:

1. Press **SET** to turn the pen **on**.
2. Press **▲** for more than 2 seconds to select range 1. Press **▲** for more than 2 seconds to select range 2.

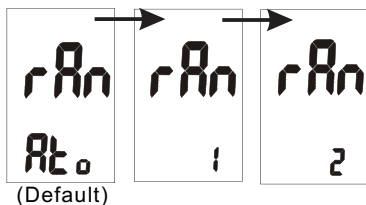

## **CALIBRATION**

### **Selecting the Calibration Standard Solution**

For best results, select a conductivity standard near the sample value that you are measuring. Alternatively, use a calibration solution value that is approximately 2/3 of the full scale of the measurement range that you plan to utilize.

For example, in the 0 to 1999 uS range, use 1413 uS solution for calibration. Do NOT reuse the calibration solution. Contaminants in the solution will affect the calibration and the accuracy. Use fresh solution each time.

Refer to the following table. For best results, use the recommended solution for various conductivity ranges



Conductivity Measuring Range		Recommended Cal. Solution Range
1	0 ~ 1999 $\mu$ S	600 ~ 1700 $\mu$ S
2	0 ~ 19.99 mS	6.0 ~ 17.00 ms

The previous calibration data will be replaced after re-calibrating. For example, if you previously calibrated the conductivity pen at 1413  $\mu$ S in the 0 ~ 1999  $\mu$ S range, when you re-calibrate at 1500  $\mu$ S again (also in the 0 ~ 1999 range), the previous 1413  $\mu$ S calibration point will be replaced in this range (0 ~ 1999  $\mu$ S). However, the pen will retain the calibration data for other ranges that have not yet been re-calibrated.

### **Note...**

The temperature coefficient of the pen defaults to 2.1% per  $^{\circ}$ C and provides good results for most applications. To reset the coefficient, see page 27. You may also refer to Appendix B on page 47 to calculate the temperature coefficient.

The default value of the reference temperature is set at 25°C. To normalize to a different value, see page 33. Determine the calibration standard value for your reference temperature before resetting the reference temperature. Contact the solution distributor for the calibration standard value of the solution.

## Selecting the Calibration Schedule

Calibration is necessary and should be performed regularly. Soak the probe for 15 minutes before calibration or measurement to minimize drift. If the pen is used in the mid ranges, calibrate the unit monthly.

If the measurement is performed at extreme temperatures or within the concentration listed below, calibrate the unit weekly.

Model	Concentration	
Conductivity Pen	< 100 uS	> 2 mS

## Conductivity Calibration

1. Place the probe into deionized or distilled water for about 30 minutes to rinse the probe.
2. Select the conductivity standard for calibration. (Refer to page 26)
3. Pour 3 cm (deep) of calibration solution into two separate containers (A & B).
4. Press **SET** to turn the pen **on**. Press **CAL** for more than 2 seconds to enter Calibration Mode.
5. Rinse the probe in one of the containers. Gently stir the probe.
6. Dip the rinsed probe into the other container. Tap the probe on the bottom of the container to remove air bubbles. Let the probe stabilize to the solution temperature (allow 15 minutes).

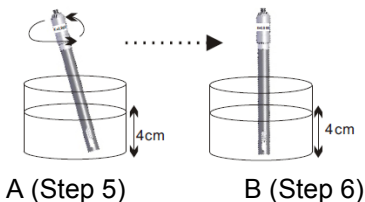

7. Press **CAL** for more than 2 seconds to begin calibration. The conductivity value of the solution will flash on the LCD.
8. Press ▲ or ▼ to adjust the value on the primary display to match the value of the standard buffer. You can adjust the conductivity reading  $\pm 30\%$  from the detected value. If the detected value and the standard value differ by more than  $\pm 30\%$ , clean or replace the pen.

Example:

Standard: 10  $\mu\text{S}$ ; Detected value: 19  $\mu\text{S}$

Adjustable range:  $\pm 5.7 \mu\text{S}$  ( $19 \times 30\%$ )

Under the above situation, the values differ by over 30%.

### **Note...**

If the standard value is over the measuring range or 10% less, the displayed value will be equal to the range limit or 10% of the range limit.

Example 1:

Standard: 22  $\mu\text{S}$ ; Detected value: 19  $\mu\text{S}$

Adjustable range:  $\pm 5.7 \mu\text{S}$  ( $19 \times 30\%$ )

Although the values differ less than 30%, the 22 uS is still over the range limit. The maximum input value is 19.99 uS.

Example 2:

Standard: 1.6 mS; Detected value: 2.1 mS

Adjustable range:  $\pm 0.63$  mS ( $2.1 \times 30\%$ )

Although the measured value differs less than 30%, the 1.6 mS is still less than the 10% range limit (1.99). The maximum input value is 1.99 mS.

9. When "CAL" stops flashing on the LCD, press **SET** for less than 1 second to confirm the value. The pen will return to Measurement Mode. To exit Calibration Mode without saving, press **SET** for more than 2 seconds. This allows you to retain the pen's previous calibration data for the current range as you proceed. If "CAL" flashes on the LCD continually, check that the calibration solution is stable and that the input value (Step 8) is correct.
10. Repeat Steps 1-9 for other ranges as needed.

## Note...

When the pen is switched from Measurement Mode to Calibration Mode, it will display the factory default value. Therefore, if the pen was previously calibrated, the display may appear to jump to the factory default value when entering Calibration Mode

## MEASUREMENT PROCEDURES

1. Remove the probe cover from the pen.

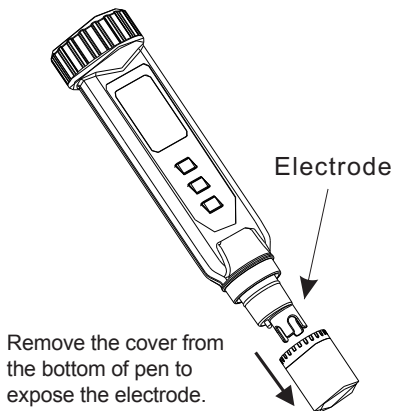

2. Press **SET** to turn the pen **on**.
3. The pen defaults to auto-ranging mode. The auto-ranging function determines and selects a range that will provide the greatest resolution and accuracy.
4. The pen also provides a manual range option. For example, to view a reading of 0.50 mS rather than 500  $\mu$ S: From Measurement Mode, press  $\blacktriangle$  for more than 2 seconds to select the 19.99 mS range. See page 31 for instructions on manually selecting the range.

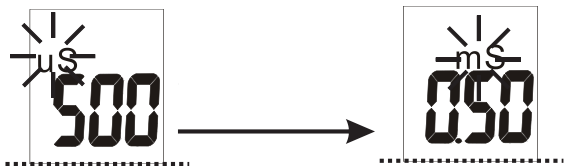

### Note...

Accuracy is a percent of full-scale; use your pen in the lowest range to achieve the greatest accuracy. Error codes E02/E03 will appear on the LCD if the measured value is below or above the limit value. Please re-select the range.

5. Set the temperature coefficient to the correct value. The pen defaults to 2.1% per °C, which will typically provide good results. See page 27 to reset the temperature coefficient.
6. Select the reference temperature. The pen defaults to 25°C. To more than 2 seconds to select the 19.99 mS range. See page 26 for instructions on manually selecting the range. normalize to 20°C instead, see page 26.
7. Rinse the probe tip with de-ionized or distilled water before use to remove any impurities adhering to the probe. If the probe tip is dehydrated, soak it for 30 minutes to prevent contaminants from slowing down the measurement and accuracy.
8. Immerse the probe tip completely into the sample. Ensure that there are no air bubbles trapped in the probe slot. Gently stir the probe to remove air bubbles, ensuring that the probe tip is submerged while stirring.



9. Stir the probe gently to create a uniform sample. Wait about 15 minutes for the reading to stabilize.
10. The unit of measure will flash on the LCD to indicate that the pen is in Measurement Mode. When the reading is stable, the unit of measure will stop flashing.



## Hold Function

1. Press **HLD** to freeze the current readings on the display. "Hold" will appear on the LCD.
2. Press **HLD** again to release the hold function.



## SPECIFICATIONS

Accuracy	$\pm 1\%$ Full Scale $\pm 1$ digit
Range	0 ~ 1999 $\mu$ S or 0 ~ 19.99 mS
Resolution	1 $\mu$ S or 0.01 mS
Temperature Accuracy	$\pm 2^{\circ}$ F $\pm 1^{\circ}$ C
Temperature Resolution	0.1 $^{\circ}$ C/ $^{\circ}$ F
Calibration	One point per range
Temperature Coefficient	0 ~ 4.0%/ $^{\circ}$ C
Reference Temperature	20 $^{\circ}$ C or 25 $^{\circ}$ C
Operating Temperature	0~50 $^{\circ}$ C (32~122 $^{\circ}$ F)
Battery Life	>80 hours continuous use
Weight	2.5 oz (68 g)
Dimensions	6 $\frac{1}{2}$ " x 1 $\frac{1}{2}$ " x 1 $\frac{1}{2}$ " (165 x 38 x 38 mm)

## ERROR CODES

### Conductivity

- - - The pen is in manual ranging 1 but the conductivity measurement is higher than 1999  $\mu\text{S}$ ; Press  $\blacktriangle$  for more than 2 seconds to change to manual ranging 2 or auto-ranging mode.
- E03 The conductivity value is over the range limit (19.99 mS) or the pen is damaged; Put the pen in standard buffer solution (the buffer concentration must be lower than the range limit). If E03 still appears, send the pen to Sper Scientific for repair.
- E04 Error in measuring original data (damaged temperature sensor or temperature out of specifications) results in this conductivity value error; Refer to the temperature error codes (page 44). E04 will disappear when the temperature error is resolved.

## Temperature

- E01 The temperature circuit is damaged; Send the pen to Sper Scientific for repair.
- E02 The temperature value is below the range limit ( $0^{\circ}\text{C}$ ) or the temperature circuit is damaged; Place the pen in room temperature for 5 minutes, if E02 still appears, send the pen to Sper Scientific for repair.
- E03 The temperature value is above the range limit ( $50^{\circ}\text{C}$ ) or the temperature circuit is damaged; Place the pen in room temperature for 5 minutes, if E03 still appears, send the pen to Sper Scientific for repair.

# Appendices

## APPENDIX A:

Program	Function	Default	Note
P1.1	Select °C/°F	°C	Temp unit
P1.2	Reference Temperature	25°C	Selectable 25°C or 20°C
P1.3	Temperature Coefficient	2.1% /°C	Adjustable 0.4 ~ 10%
P3.1	Factory Default	NO	Retain your current settings
P4.1	Viewing previous calibration data	----	No cal data for 1st range
P4.2	Viewing previous calibration data	----	No cal data for 2nd range

## **APPENDIX B:**

### **Temperature Effect**

Conductivity measurements are temperature dependent; if the temperature increases, conductivity increases. For example, the conductivity measured in a 0.01 M KCl solution at 20°C is 1.273 mS/cm, whereas at 25°C, it is 1.409 mS/cm.

The concept of reference temperature (normalization temperature) was introduced to allow the comparison of conductivity results obtained at different temperatures. The reference temperature is usually 20°C or 25°C. The pen measures the actual conductivity and temperature, then converts it to the reference temperature using a temperature correction function and displays the conductivity at the reference temperature. It is mandatory to associate the temperature together with a conductivity result. If no temperature correction is applied, the conductivity

is the value taken at the measurement temperature. The Large Display Salinity (Model 850036) and Conductivity (Model 850037) Pens automatically use linear temperature correction.

## Linear Temperature Correction

In moderately and highly conductive solutions, temperature correction can be based on a linear equation involving a temperature coefficient ( $\theta$ ). The coefficient is usually expressed as a conductivity variation in  $\%/^{\circ}\text{C}$ . Linear temperature correction is used for saline, acids, and leaching solutions.

$$K_{T_{\text{ref}}} = \frac{100}{100 + \theta \cdot (T - T_{\text{ref}})} \cdot K_T$$

Where:

$K_{T_{\text{ref}}}$  = Conductivity at  $T_{\text{ref}}$

$K_T$  = Conductivity at  $T$

$T_{\text{ref}}$  = Reference temperature

$T$  = Sample temperature

$\theta$  = Temperature coefficient



### **Note...**

The correction is accurate only within a limited temperature range around T1 and T2. The greater the difference between T and Tref, the higher the risk of error.

### **Calculating Temperature Coefficients ( $\theta$ )**

By measuring the conductivity of a sample at temperature T1 close to Tref and another temperature T2, you can calculate the temperature coefficient by using the following equation:

$$\theta = \frac{(K_{T2} - K_{T1}) \cdot 100}{(T2 - T1) \cdot K_{T1}}$$

T2 should be selected as a typical sample temperature and should be approximately 10°C different from T1. The temperature coefficients of the following electrolytes generally fall into the following ranges:

Acids: 1.0 - 1.6%/°C

Bases: 1.8 - 2.2%/°C

Salts: 2.2 - 3.0%/°C

Drinking water: 2.0%/°C

Ultra-pure water: 5.2%/°C

Average temperature coefficients of standard electrolyte solutions are expressed as %/°C of the conductivity value at 25°C.

Temp Range °C	KCl 1M	KCl 0.1 M	KCl 0.01 M	Saturated NaCl
15 ~25	1.725	1.863	1.882	1.981
15 ~ 25 ~35	1.730 (15 ~ 27°C)	1.906	1.937 (15 ~ 34°C)	2.041
25 ~ 35	1.762 (25 ~ 27°C)	1.978	1.997 (25 ~ 34°C)	2.101

# **Battery Replacement, Maintenance, & Troubleshooting**

## BATTERY REPLACEMENT

1. Press **SET** to turn the pen **off**.
2. Remove the battery cover located on the top of the unit by rotating counterclockwise. Do NOT discard the black washer.
3. Remove the old batteries and replace with 4 new LR44 batteries, ensuring correct polarity.
4. Replace the battery cover by rotating in the clockwise direction.

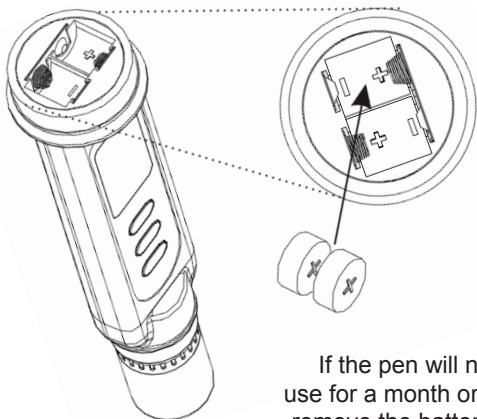

### **Note...**

If the pen will not be in use for a month or longer, remove the batteries and replace when ready to use the pen.

## **MAINTENANCE**

Ensure that the probe is clean before use and storage. To clean:

1. Remove the probe cap.
2. Rinse the probe carefully in deionized water, replace the cap, and store dry in an environment of 0 ~ 50°C.

### **Note...**

If the probe has been exposed to a solvent that is immiscible with water, clean the probe with a solvent that is miscible with water (i.e., ethanol or acetone), then carefully rinse with water.

## **TROUBLESHOOTING**

### **Pen does not turn on:**

1. Press **SET** for more than 1 second.
2. Check that the batteries are in place, making good contact, and placed with correct polarity.
3. Replace with new batteries and try again.
4. Remove the batteries for one minute and then replace the batteries.

### **Display disappears:**

If the low battery icon appears on the LCD before the display disappears, replace with new batteries.

### **Air bubbles adhering to the probe:**

It is typical for air bubbles to adhere to the large slot in the probe. These air bubbles will greatly affect the accuracy and should be removed.

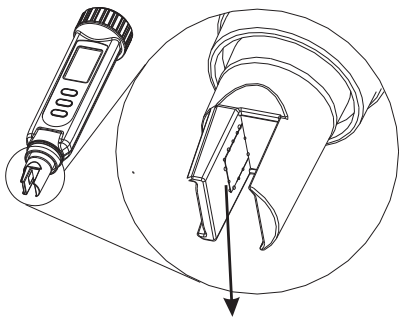

**Many air bubbles adhered!**

To remove the air bubbles:

1. Stir the probe.
2. Dip the probe into the solution at an oblique angle (at a slant, not perpendicular to solution). Dipping the probe perpendicularly will cause air bubbles to form.
3. Soak the probe in solution for 15-30 minutes. Inspect the probe carefully for air bubbles.
4. If air bubbles remain on the probe, tap the bottom of the container gently and stir the probe.
5. If the preceding methods fail, remove the probe from the solution and blow on the probe to remove the air bubbles.

## WARRANTY

Sper Scientific warrants this product against defects in materials and workmanship for a period of **one (1) year** from the date of purchase, and agrees to repair or replace any defective unit without charge. If your model has since been discontinued, an equivalent Sper Scientific product will be substituted if available. This warranty does not cover probes, batteries, battery leakage, or damage resulting from accident, tampering, misuse, or abuse of the product. Opening the pen to expose its electronics will void the warranty.

To obtain warranty service, ship the unit postage prepaid to:

SPER SCIENTIFIC, LTD.  
8281 E. EVANS RD., SUITE #103  
SCOTTSDALE, AZ 85260

Be sure to include your name, address, phone number, and a detailed explanation of why you are returning the item. Mail your warranty card within 10 days or register online at: [www.sperscientific.com](http://www.sperscientific.com).

Revised 03/15/13