

Bluetooth Datalogging Thermo-Hygrometer

800020

Instruction Manual

SPER
SCIENTIFIC

Environmental Measurement Instruments

TABLE OF CONTENTS

INTRODUCTION	3
FEATURES.....	4
MATERIALS SUPPLIED	4
FRONT PANEL DESCRIPTION.....	5
LCD DISPLAY	6
SET UP	7
MEASUREMENT PROCEDURES.....	12
SOFTWARE INSTALLATION.....	17
DATALOGGING.....	19
POWER SUPPLY.....	24
CARE AND MAINTENANCE.....	25
SPECIFICATIONS	26
WARRANTY	28

INTRODUCTION

This Sper Scientific Bluetooth Datalogging Therm-Hygrometer with dewpoint and wet bulb (Model 800020) accurately measures the ambient air while streaming instantly to any iOS or Android smartphone. This multiparameter meter also has a contact thermocouple port to detect surface temperatures. All parameters have an optional audible and visible alarm that can be seen at a distance. The large backlit LCD simultaneously displays all values while concurrently streaming to a smartphone and/or a computer. Up to 32,000 complete data records with GMP compliant date/time stamping can be stored in the meter and later downloaded or conveniently e-mailed if a PC is unavailable at the time. All data can be viewed and stored in Excel format or you can use our unique graphing tools in the included software to view and analyze the data. Calibrate to known standards using the offset function for humidity, ambient air temperature, and ice-point. The meter comes ready to use with a protective foam-lined carrying case, Type K beaded wire probe, micro USB cable, a built-in easel stand, 4 AAA batteries, and instruction manual.

FCC ID: 2AB7UBTXX0

This device and enclosed comply with part 15 of the FCC Rules. Operation is subject to the two following conditions: (1) this device may not cause harmful interference, and (2) this device must accept any interference received, including interference that may cause undesired operation.

FEATURES

- Large LCD screen
- Measures in °C, °F, or Kelvin
- Customizable high and low alarms for all parameters
- Maximum/minimum/average values
- Offset function for all parameters
- 32,000 data points
- Direct upload of data to EXCEL, text, or graph files
- Customizable data graphing
- Automatic shutoff
- Backlight
- Bluetooth® streaming and data sharing

MATERIALS SUPPLIED

- Datalogging Thermometer
- Micro USB Cable
- One K-type Beaded Wire Probe
- Free Software Download at:
www.sperdirect.com/software.htm
- Free App Download at:



- Instruction Manual
- Four AAA batteries
- Carrying Case
- Bluetooth® 7-pin adapter

FRONT PANEL DESCRIPTION

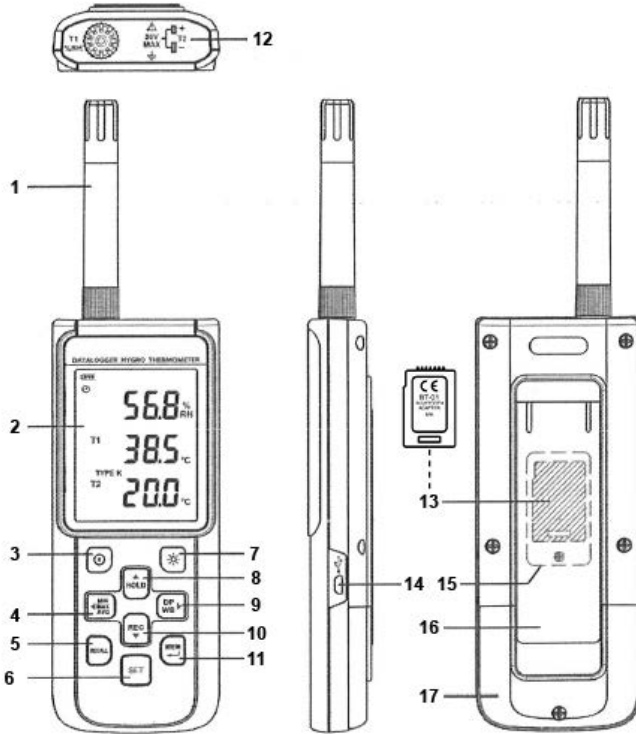

- | | |
|---|-----------------------------------|
| 1. Ambient Temperature and Humidity Probe | 9. RIGHT Arrow and UNIT Selection |
| 2. LCD Display | 10. DOWN Arrow and REC Button |
| 3. POWER Button | 11. MEM Button |
| 4. LEFT Arrow and MIN/MAX | 12. Thermocouple Input |
| 5. RECALL Memory Button | 13. Bluetooth® Chip |
| 6. SET Button | 14. Micro USB Port |
| 7. Backlight Button | 15. Bluetooth door |
| 8. UP Arrow and HOLD Button | 16. Tilt Stand |
| | 17. Battery Chamber |

LCD DISPLAY

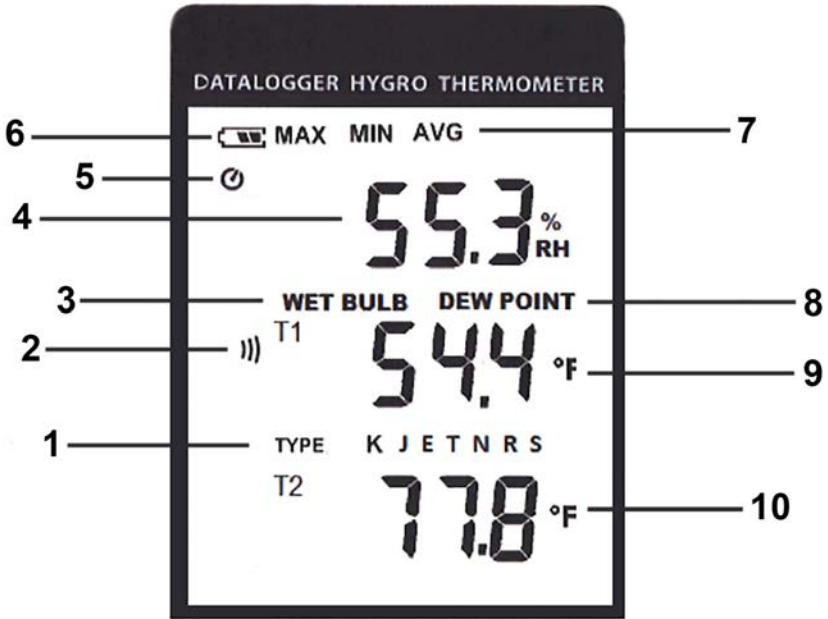

1. Thermocouple Type Selected
2. Bluetooth Activated
3. Wet Bulb Active on T1
4. Current RH Reading
5. Auto Power-off is Enabled
6. Low Battery Indicator
7. Min/Max/Average Activated
8. Dew Point Active on T1
9. Current Ambient Air T1 Reading
10. Current Thermocouple Reading T2

SETUP

Note...

Install the Bluetooth adapter as described on page 11.

Meter On and Off

1. Press **POWER** to turn the meter **on**.
2. Press and hold **POWER** for 3 seconds to turn the meter **off**.

Setup Mode

1. Press **POWER** to turn the meter **on**.
2. Press **SET** to enter Setup Mode.
3. Press **MEM** to save each setting choice and continue cycling through the setup options.

Note...

After each change is made, pressing **SET** will also save the setting but will exit Setup Mode. The meter will return to Normal Mode if the **SET** button is pressed..

Bluetooth Selection

1. Press **SET** to enter Setup Mode.
2. “bluetooth” appears on the display along with the word “on” or “off”. Press **▲** or **▼** to select “on”
3. Press **MEM** to save the selection and toggle to the next setting. Otherwise, press **SET** to exit setup mode.

Thermocouple Type

1. Press **SET** to enter Setup Mode.
2. Press **MEM** to toggle through the settings until “Type” appears on the display along with the thermocouple type.
Press **▲** or **▼** to cycle through K, J, E, T, N, R, and S types.
3. Press **MEM** to save the selection and toggle to the next setting. Otherwise, press **SET** to exit setup mode.

Unit of Measure

1. Press **SET** to enter setup mode.
2. Press **MEM** to toggle through the settings until “Unit” appears on the display along with flashing symbols for °C, °F, or K. Press ▲ or ▼ to cycle to your desired temperature unit.
3. Press **MEM** to save the selection and toggle to the next setting. Otherwise, press **SET** to exit setup mode.

Time Interval

The time interval range for data storing is 1 second to 60 minutes 59 seconds. The time interval defines how often a reading is taken during record mode.

1. Press **SET** to enter setup mode.
2. Press **MEM** to toggle through the settings until “Int” appears on the display along with the time interval in minutes and seconds. The minutes flash on the display.
3. Press ▲ or ▼ to adjust the minutes.
4. Press ◀ or ▶ to move the cursor to the required number of seconds. The seconds will flash.
5. Press ▲ or ▼ to adjust the seconds.
6. Press **MEM** to save the selection and toggle to the next setting. Otherwise, press **SET** to exit setup mode.

Offset Values

All parameters can be adjusted to compensate for probe errors. The offset range is $\pm 5^{\circ}\text{C}$ or $\pm 9^{\circ}\text{F}$.

1. Press **SET** to enter setup mode.
2. Press **MEM** to toggle through the settings until OFFSET appears at the bottom of the screen. Press ▲ or ▼ to increase or decrease the offset value as compared to a known standard such as an ice bath or humidity salt chamber.

3. Press ◀ or ▶ to advance to the next parameter.
4. Press **MEM** to save the selection and toggle to the next setting. Otherwise, press **SET** to exit setup mode.

Audible and Visible Alarms

High and low alarm values may be set for all parameters.

1. Press **SET** to enter setup mode.
 2. Press **MEM** to toggle through the settings until **ALARM** appears at the bottom of the screen. Press ▲ or ▼ until the word "On" appears on the screen.
 3. Press **MEM** to advance into the alarm settings.
 4. Use the ◀ or ▶ to advance through the placeholders and the ▲ or ▼ buttons to change the numbers. Press **MEM** to save the selection and toggle to the next parameter.**
- **Note: The alarm function is either on for all parameters or off for all parameters. The best way to alarm only one parameter is to set the values of the unwanted parameters to something not possible during your measurement period. For example, if you don't want the humidity to alarm, set the high for 99% and the Low for 0%.
5. Continue to set the High and Low alarms using the ▲ or ▼ buttons for each parameter.
 6. Press **MEM** to save the selection and toggle to the next setting. Otherwise, press **SET** to exit setup mode.

Programming the Automatic shut off

1. Press **SET** to enter setup mode.
2. Press **MEM** to toggle through the settings until the auto-power off icon appears in the upper left corner along with the word “off” or “on.”
3. Press ▲ or ▼ until the word “On” appears on the screen.
4. Use the ◀ or ▶ arrows to toggle through the available shut off times. The meter can be preset to shut off automatically after 10 minutes, 30 minutes, or hour increments of 1, 2, 4 or 8.
5. Press **MEM** to save the selection and toggle to the next setting. Otherwise, press **SET** to exit setup mode.

Setting the Date and Time

1. Press **SET** to enter setup mode.
2. Press **MEM** to toggle through the settings until the Year, Date, and time appear on the screen, along with the word “SET”.
3. Press ▲ or ▼ to adjust the year.
4. Use the ◀ or ▶ to advance to the date.
5. Press ▲ or ▼ to adjust the date and time after advancing to it.
6. Once the date and time have been set, press **MEM** to save the selection and toggle to the next setting. Otherwise, press **SET** to exit setup mode.

BLUETOOTH ADAPTER INSTALLATION

1. Lift the tilt stand to expose the single screw located behind the stand.
2. Remove the screw and plastic cover.
3. Place the Bluetooth® adapter into the housing with the label facing up.
4. Slide the adapter up to connect the pins of the adapter with the pins of the meter.
5. Screw the plastic cover back on to the meter.
6. The meter is now Bluetooth capable.***

***Please Note that While most Smartphones have built-in Bluetooth capability, many PC's **DO NOT**.

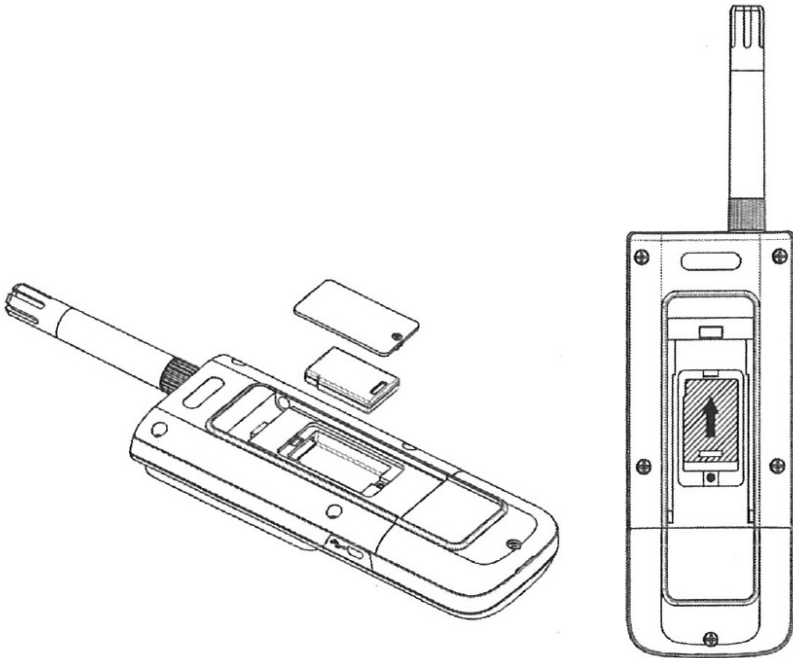

MEASUREMENT PROCEDURES

Backlight

1. Press the backlight button to illuminate the LCD display.
2. The backlight will shut off automatically after 30 seconds, or press the backlight button to turn it off sooner.

Taking Readings

1. Press **POWER** to turn the meter **on**.
2. Readings for relative Humidity are automatically displayed at the top of the screen.
3. The Air Temperature value, Dew Point, and Wet Bulb values share the central (T2) location. To toggle between them, press **DP/WB**.

Data Hold

Note...

The **MIN/MAX/AVG**, **DP/WB**, **RECALL** and **SETUP** buttons on the meter are disabled during data hold.

1. Press **HOLD** to freeze the reading on the display. “Hold” appears at the top of the LCD.
2. Press **HOLD** to return to Normal Mode.

Maximum/Minimum/Average Mode

Note...

Viewing the maximum, minimum and average values will not interrupt temperature measurement. The maximum, minimum and average values will continue to be updated when in record mode.

1. Press **MIN/MAX/AVG** to enter Maximum/Minimum Mode and record maximum, minimum and average values. “MAX” displays along with the maximum values for each parameter.

2. Press **MIN/MAX/AVG**. “MIN” displays along with the minimum values for each parameter.
3. Press **MIN/MAX/AVG**. “AVE” displays along with the average for the values.
4. Press **MIN/MAX/AVG**. “MAX,” “MIN” and “AVG” blink and the meter displays real-time data.
5. Press and hold **MIN/MAX/AVG** for 2 seconds to return to Normal Mode.

Memory Function

To save a reading:

1. Press **MEM** to save the reading on the display.
2. The “MEM” symbol light up for 2 seconds to show the serial number of the saved reading, from 00 to 99.

To recall a reading

1. Press **RECALL**. The “RECALL” symbol lights up on the display, along with the associated serial number.
2. Use the **▲**, **▼**, **◀** or **▶** buttons to select a saved memory serial number. The LCD shows the time of the reading for 2 seconds followed by the saved data.
3. Press **RECALL** to return to Normal Mode.

Clearing Readings in Memory

1. Press and hold **POWER** for 3 seconds to turn the meter **off**.
2. Press and hold **MEM**.
3. While continuing to hold **MEM**, press and hold **POWER** to turn the meter **on**.
4. Continue to hold **MEM** and **POWER**. The meter displays “MEM,” “Clr” and “SuRE 5” and counts down to zero.
5. “CLr 0” displays as the meter begins erasing records.

6. To exit the process without clearing the memory, release the **MEM** button before “**SUR E 0**” displays.

Datalogging Data

Note... Most of the buttons on the meter are disabled during datalogging. All settings must be selected before recording begins.

1. Press **REC** to begin recording the readings. “REC” displays on the LCD. If 32,000 readings have been stored for a parameter, “FULL” blinks on the LCD.
2. Press **REC** to stop recording.
3. After the recording is complete, you have two options for retrieving it.

Option 1: Download the data to a smartphone by following the instructions on page 15.

Option 2: Connect the meter to a PC using the included micro USB cable. Retrieve the data using the PC software as described on page 23.

Note... the meter will not record if battery power is extremely low.

Clearing the Recorded Data

1. Press and hold **Power** for 3 seconds to turn the meter **off**.
2. Press and hold **REC**.
3. While continuing to hold **REC**, press and hold **POWER** to turn the meter **on**.
4. Continue to hold **REC** and **POWER**. The meter displays “**REC**”, “**Clr**” and “**SUR E 5**” and counts down to zero.
5. To exit the process without clearing the memory, release the **REC** and **POWER** buttons before “**SUR E 0**” displays.

USING THE SMARTPHONE APP

1. Download the Android or iOS application onto your phone. Search for “TESTLINK RH” in the Apple, or Google Play store.



2. Press **POWER** to turn the meter **on**.
3. Ensure the Bluetooth® function is turned on in the meter’s settings. The instructions for doing this are on page 7 of this manual.
4. Pair the meter with the cell phone’s Bluetooth® under the settings menu on the phone. Since the phone can remember several meters, it is important to note that the meter’s name will match the serial number of the Bluetooth® adapter installed inside the meter.
5. Open the application on the phone. If the meter is not yet paired, the application will automatically search for a meter. see image below.

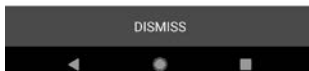

6. Once the meter is paired, you will see real-time readings, graphs, and download data from the meter by simply clicking the icons for each of these features.



7. Data can be saved, retitled, e-mailed, and sent via text message from the application. See image below.

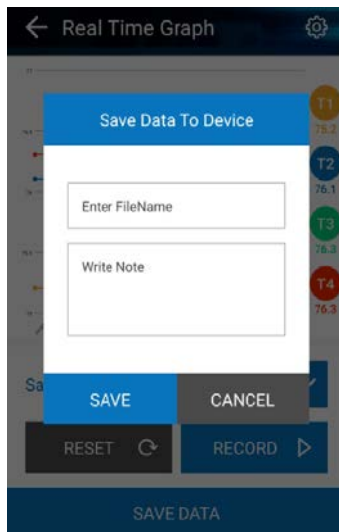

SOFTWARE INSTALLATION

System Requirements	Windows XP / VISTA / 7 / 8 / 10
Minimum Hardware Requirements	PC or laptop ≥50 MB hard disk space to install 800020 software, Screen resolution ≥ 1024 x 768

Note...

Different computer systems may require slightly different installation steps than those below.

1. Download the software from the Sper Scientific website at ***www.sperdirect.com/software.htm***
If Windows does not run the Setup.exe automatically, open the download folder and double-click the file from there.
2. Select **Yes** to allow the program Setup.exe to make changes to your computer.
3. Select **Next** to start the installation.
4. Select the folder to install the files and click **Next**.
5. Select the location for the program shortcuts and click **Next**.
6. Click **Next** to begin the configuration.
7. Click **Finish**. The software is now installed along with a help file.

Uninstalling the Software

If you wish to remove software from your computer, use one of the following methods. Note that your system may require slightly different steps.

1. Click on the **Start Menu**.
2. Select **Control Panel**.
3. Launch the **Add/Remove Programs**.
4. Highlight **800020**.
5. Click on **Add/Remove**.
6. Click **Next**.
7. Click **Next**.
8. Click **Finish**.

OR

1. Click on the **Start Menu**.
2. Select **Control Panel**.
3. Select **Programs and Features**.
4. Double-click on **800020**.
5. The Installation Dialog Box appears. Select **Uninstall** and click **Next**.
6. Click **Next**.
7. Click **Finish**.

PROCESSING DATA WITH PC SOFTWARE

Recording Real-Time Data in Graph Form

1. Press **POWER** to turn the meter on.
2. Connect the meter to the computer's Bluetooth®. This is different for some PC's, but is usually done through the settings menu under **Add a Device**. On some computers, the device may be recognized with both a headphone icon and a keyboard icon (see image, below). If this is the case, always choose the headphone icon.

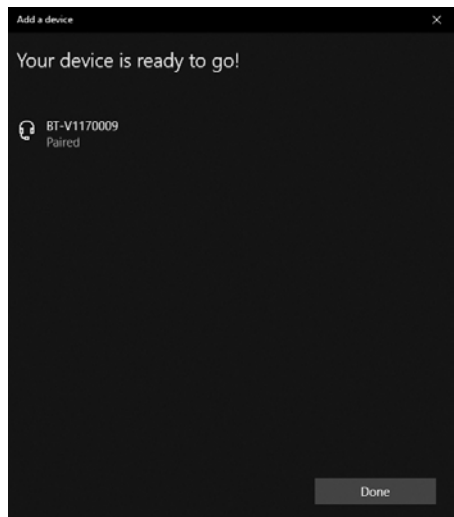
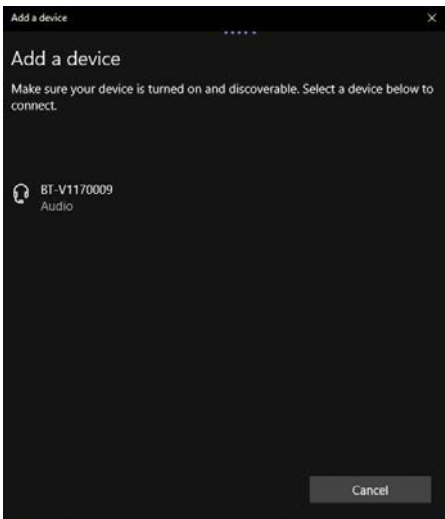





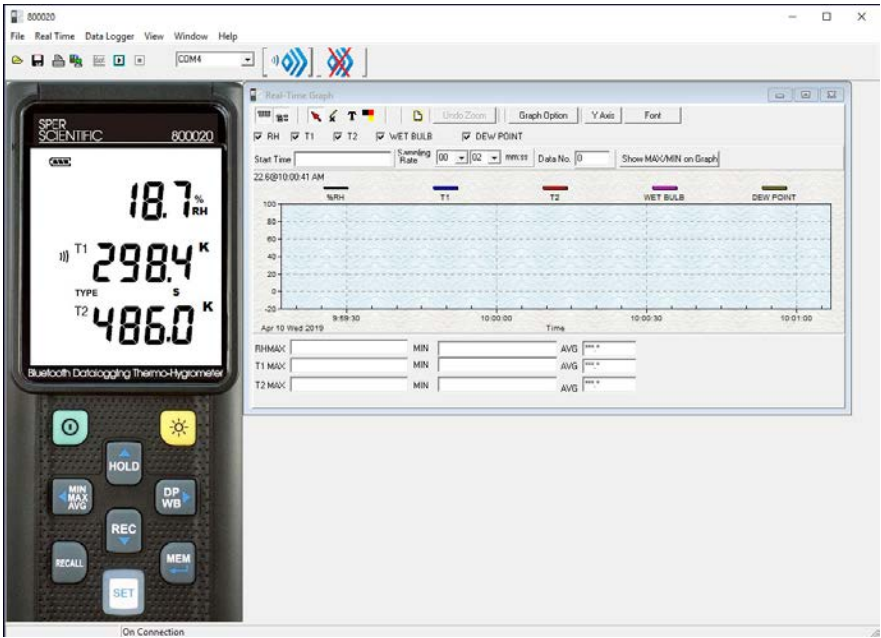



3. Insert the thermocouple(s) into the appropriate port(s)
4. Open the Sper Scientific **software**. An image of the meter displays along with a graph.

5. Connect the software to the meter by clicking the **Bluetooth icon** (see the image, below). Please note that the meter's Bluetooth must be on to connect to the software. Do this by following the instructions on page 7 of this manual.



Tool Bar Options

 	Connect or disconnect Bluetooth
	Hide or display the statistics above the graph (Statistic 1.)
	Hide or display the statistics below the graph (Statistic 2.)
	Restore normal cursor.
	Change cursor to an “X.” Click anywhere on the graph to mark it with an “X.” This option is not available when “Split” is selected.
	Change cursor to an “I.” Click anywhere on the graph to add an annotation. This option is not available when “Split” is selected.
	Set annotation color, ensuring sufficient contrast with the graph background.
Split	Separate or combine the four parameters in the graph. When “Split” is not selected the graph will use T1 as the Y axis.

Viewing the Graph

- **To zoom in:** Press the left mouse button and drag the cursor to select the new area.
- **To zoom out:** Click **Undo Zoom**.

Customizing the Graph

1. Click **Graph Option** to open the **Customization Menu**.
This allows you to specify the channel displayed, modify the graph style, add a title and subtitle, maximize the graph and export the graph to the clipboard, a file or a printer.
2. Click **Font** to select the font name, style and size for annotations.
3. Click **Y Axis** to customize the maximum and minimum values on the graph.

Saving Real-Time Data

1. Click the graph window you want to save. The selected graph window will become active.
2. Click **File** and select **Save**, or simply click the disc icon.
3. Enter the file name and file type extension:

File Type	Extension
Graph file. This file type can only be used in 800020.	*.ghf
Text file	*.txt
EXCEL format file	*.csv

4. Click **Save**.

Printing the Graph

1. Click **File** and select **Print**, or simply click the printer icon.
2. Select the destination printer and click **OK**.

Downloading Recorded Data

Select **Data Logger** from the main menu bar or click  (the datalogger icon) under the main menu. An indicator shows the loading progress.

- The left side of the screen will display the number of data sets with detail information for each set.
- The first data set will appear in the graph on the right side.
- Click any data set to graph that set.

POWER SUPPLY

Battery Power

This meter uses four AAA batteries. To install the batteries before first use:

1. Lift the tilt stand on the back of the meter. Unscrew and remove the screw at the bottom of the battery cover.
2. Lift off the battery cover.
3. Insert four new AAA batteries, ensuring correct polarity.
4. Replace the battery cover and reinstall the screw.

Replace the batteries when the low-battery icon blinks on the LCD.

Note...

Before replacing the batteries, turn the meter **off** and disconnect the temperature probes.

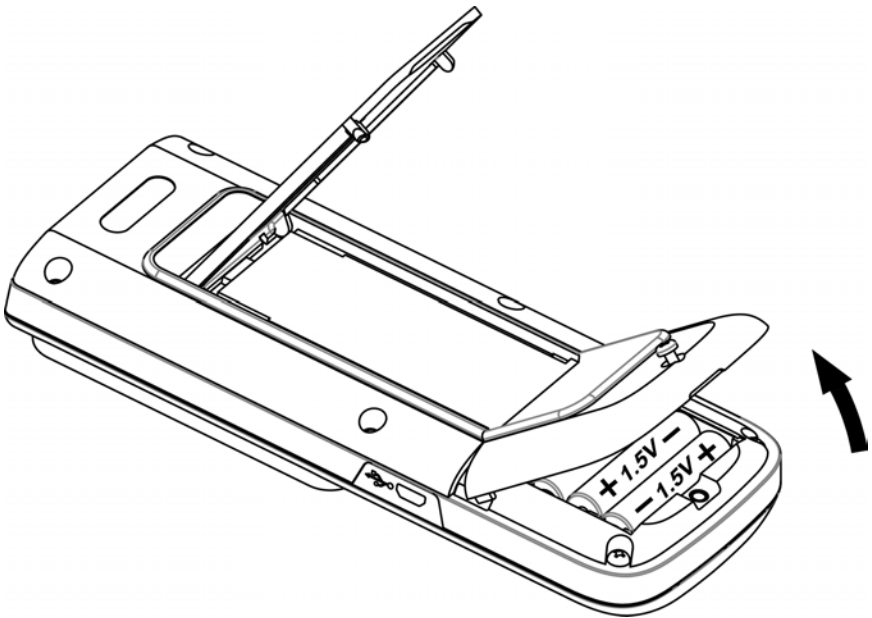

CARE AND MAINTENANCE

- Periodically wipe the meter with a dry, lint-free antistatic cloth.
- Do **not** use abrasives, solvents or cleaning agents containing carbon, alcohol or benzenes on the meter.
- Repairs or services not covered in this manual should be performed by qualified personnel only. Please contact Sper Scientific to speak with a technician.

SPECIFICATIONS

		Range	Resolution	Accuracy (excluding probe error)
Temperature	K	-200 to 1372°C -328 to 2501°F	0.1°C < 600°C 1°C ≥ 600°C	±(0.1% of reading + 0.7°C) ±(0.1% of reading + 1.3°F) Below -100°C (-148°F) ±(0.5% of reading + 0.7°C) ±(0.5% of reading + 1.3°F)
	J	-200 to 1000°C -328 to 1832°F		
	E	-200 to 750°C -328 to 1382°F	0.1°F < 1000°F 1°F ≥ 1000°F	
	T	-200 to 400°C -328 to 752°F		
	N	-200 to 1300°C -328 to 2372°F		
	R/S	0 to 1767°C 32 to 3212°F	0.2°C < 600°C 1°C ≥ 600°C 0.5°F < 1000°F 1°F ≥ 1000°F	
Temperature Coefficient		0.01% of reading + 0.05 °C (0.0028°F) per °C [<18°C (64°F) or >28°C (82°F)]		
Sample Rate		2 times per second		
Battery Type		UM-4 or AAA 1.5V battery x 4		
Battery Lifetime		Bluetooth® OFF : Approx. 100 hours (alkaline battery) Bluetooth® ON : Approx. 20 hours (alkaline battery)		
Operating Temp.		0°C to 50°C (32°F to 122°F)		
Operating RH%		10 to 90% RH (no condensing)		
Operating Temperature		0 to 50°C 32 to 122°F		
Storage Temp.		-20°C to 60°C (-4°F to 140°F)		
Storage RH%		10 to 75% RH		
Dimensions		7.36" x 2.95" x 114" (187 x 75 x 29 mm)		
Weight		10.2 oz (290 g)		

PROBE: 800020P			
Sensor Type: Semi-Conductor humidity and temperature sensor			
	Range	Resolution	Accuracy [at 23°C(73.4°F)]
RH	0 to 90%RH	0.1%RH	10%RH to 90%RH ±2.5%RH <10%RH,> 90%RH ±5.0%RH
Wet bulb	-20°C to 60°C (-4°F to 140°F)	01°C, 0.1°F	-20 to 60°C (-4°F to 140°F) ±0.8°C (±1.5°F)
Dew point	-50°C to 60°C (-58°F to 140°F)	01°C, 0.1°F	
Temperature	-20°C to 60°C (-4°F to 140°F)	01°C, 0.1°F	
Response Time (@t90)	Humidity: 60 sec. in slowly moving air Temperature: 20 sec. in slow moving air (T1)		
Sensor hysteresis:	<1.5%RH with excursion of 90% to 10% to 90%		
Temperature coefficient:	0.1 x (specified accuracy) per 1°C [<23°C(73.4°F) or >23°C(73.4°F)]		

WARRANTY

Sper Scientific warrants this product against defects in materials and workmanship for a period of **five (5) year** from the date of purchase, and agrees to repair or replace any defective unit without charge. If your model has since been discontinued, an equivalent Sper Scientific product will be substituted if available. This warranty does not cover probes, batteries, battery leakage, or damage resulting from accident, tampering, misuse, or abuse of the product. Opening the meter to expose its electronics will void the warranty. To obtain warranty service, ship the unit postage prepaid to:

SPER SCIENTIFIC LTD.

8281 E. Evans Rd., Suite #103
Scottsdale, AZ 85260
(480) 948-4448

The defective unit must be accompanied by a description of the problem and your return address. Register your product online at www.sperwarranty.com within 10 days of purchase.

